

# FALLS CREEK RANCH UNITS I, II & III AMENDED PLAT #2 PROJECT NO. 2006-0325

LOCATED IN SECTIONS 9, 16, 17, 20, & 21, TOWNSHIP 36 NORTH, RANGE 9 WEST, N.M.P.M.

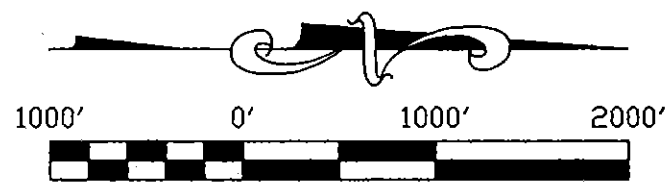
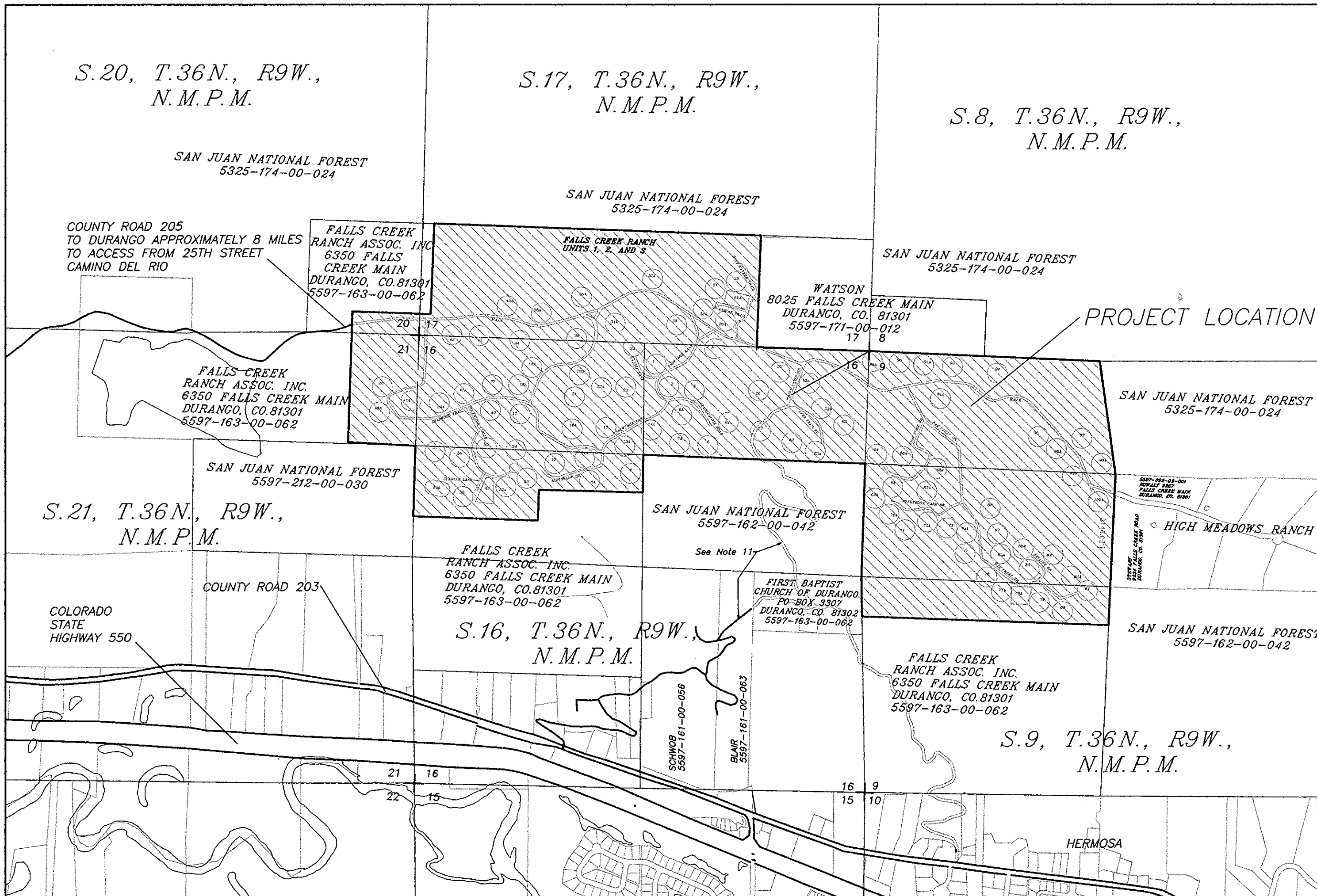

**VICINITY MAP  
SCALE 1"=1000'**

**\*GENERAL NOTES\***

1. This plat creates base lines for the future determination of lots within the limits of the Falls Creek Ranch Subdivision. The location of the lots as shown hereon is determined by the utilization of the base lines as shown hereon together with the coordinate listing as shown on the 1986 Amended Plat of Units I, II and III, Falls Creek Ranch, recorded under Reception Number 541554.
2. Reference Monuments (RM), as shown hereon, represent 1 point on the perimeter of the circle and 1 point on a 50 foot tangent to the perimeter of the circle. (See Detail "B")
3. Portions of the roads were located by survey in order to adjust the lots so that no roads encroach on the lots as shown hereon.
4. All permanent building structures have been located by survey within the lots and no encroachments exist outside the adjusted lots.

THE PURPOSE OF THIS AMENDED PLAT IS TO MOVE LOTS 4, 6, 7, 9, 11, 13, 14, 16, 17, 18, 19, 20, 22, 27, 28, 30, 32, 34, 35, 38, 39, 41, 45, 47, 48, 49, 52, 58, 59, 61, 63, 66, 67, 68, 69, 70, 72, 74, 77, 78, 82, 83, 85, 86, 89, 91, 92, 96, 98, 99, AND 100 TO CORRECT THE ENCROACHMENTS OF THE STRUCTURES INTO THE COMMON AREAS AND THE ENCROACHMENTS OF THE ROADWAYS INTO THE EXISTING LOTS.

5. Lots 49, 61, and 78's shape has changed as shown hereon.
6. Lots 6,7,11,16,19,20,32,66, and 67 were moved from the 1986 Amended Plat original monument locations to reflect the 2009 Amended Plat baseline coordinates.
7. Subject to a 60' wide Non-Exclusive Access and Utility Easement along and over the Falls Creek Main Road, together with said Falls Creek Road and more particularly described in the Amended Plat of Falls Creek Ranch, Units I, II, and III, and recorded with the Clerk and Recorder of La Plata County, Colorado under Reception No. 541554 as described in Reception No. 569192, 569191, and 569190.
8. Subject to a Mineral Resource Area, and a Geological Hazard area As described in Reception No. 401417.
9. Title work completed by Colorado Land Title Commitment Order No. L-536351 (AMENDED) provided by the client.

10. This Plat is being recorded at the request of the Falls Creek Homeowners Association for the sole purpose of correcting surveying errors on prior recorded plats of Falls Creek Ranch. All previously recorded plats and all information contained therein, including, but not limited to, easements, lot boundaries and plat notes, remain in full force and effect, except as expressly amended by this Plat. This plat was reviewed by the Board of County Commissioners in accordance with section 102-30(a) of the La Plata County Land Use Code.
11. A written unrecorded License Agreement, written as a revocable offer of use dated October 31, 2006, between the First Baptist Church of Durango, the Red Ridge Property Owners Association, and the Falls Creek Ranch Association, Inc. exists over the use of the Fire Ingress/Egress roadway as shown hereon.

NOTICE: ACCORDING TO COLORADO LAW YOU MUST COMMENCE ANY LEGAL ACTION BASED UPON ANY DEFECT IN THIS SURVEY WITHIN THREE (3) YEARS AFTER YOU FIRST DISCOVERED SUCH DEFECT. IN NO EVENT, MAY ANY ACTION BE BASED UPON ANY DEFECT IN THIS SURVEY BE COMMENCED MORE THAN TEN (10) YEARS FROM THE DATE OF THE CERTIFICATION SHOWN HEREON.

**CERTIFICATE OF OWNERS:**

KNOW ALL MEN BY THESE PRESENTS: That Falls Creek Ranch Association, Inc., a Colorado nonprofit corporation, being the legal and record owner of the following described tract of land:

Being a portion of Sections 9, 16, 17, 20 and 21, all in Township 36 North, Range 9 West, New Mexico Principal Meridian, in La Plata County, State of Colorado, as described by Deed recorded in the Office of the La Plata County, Colorado, Clerk and Recorder, under Reception Number 502627, and more particularly described as follows:

All of Falls Creek Ranch, Inc. Unit I, Unit II, and Unit III, as shown on 1986 Amended Plat of Falls Creek Ranch, Units 1, 2 & 3, recorded December 22, 1986, under Reception Number 541554 in the Office of said Clerk and Recorder, to wit:

**BEGINNING** at the North 1/4 Corner of said Section 16, being a point on the boundary of said Falls Creek Ranch Unit II; Thence North 89°59'24" West, along the South line of said Section 9, a distance of 1321.13 feet to the West 1/16 Corner common to said Sections 16 and 9; Thence South 00°19'32" West, along the West line of the East 1/2 of the Northeast Quarter of said Section 16 a distance of 2606.49 feet to the Center-West 1/16 Corner of said Section 16; Thence North 88°34'15" East, along the South line of the Southeast 1/4 of the Northwest Quarter of said Section 16, a distance of 439.74 feet; Thence South 00°29'15" East, a distance of 1216.41 feet; Thence North 90°00'00" East, a distance of 359.16 feet to a point whence the Northeast Corner of said Section 16 bears North 37°49'23" East, a distance of 4985.45 feet; Thence South 00°00'03" East, a distance of 1461.17 feet to the South line of said Section 16; Thence South 89°48'52" West, along the South line of said Section 16, a distance of 824.38 feet to the West 1/16 Corner common to said Sections 16 and 21; Thence South 00°56'24" West, a distance of 790.26 feet; Thence South 90°00'00" West, a distance of 1537.00 feet; Thence North 00°00'00" West, a distance of 914.46 feet; Thence North 89°38'14" West, a distance of 1062.87 feet to the West line of Tract 38 of said Section 17, whence AP3 of said Tract 38 bears South 00°08'41" West, 132.11 feet; Thence North 00°08'40" East, along the West line of said Tract 38, a distance of 3830.72 feet to AP2 of said Tract 38, said point being coincident with AP5 of Tract 37 of said Section 17; Thence South 89°47'03" East, along the North line of said Tract 38, a distance of 1309.91 feet to AP1 of said Tract 38, said point being on the West line of said Section 16; Thence North 00°03'43" East, along the West line of said Section 16, a distance of 1319.61 feet to the Northwest Corner of said Section 16, said point being common with Sections 8, 9, 16 and 17; Thence North 00°34'09" East, along the West line of said Section 9, a distance of 2701.78 feet to the West Quarter Corner of said Section 9; Thence North 80°06'18" East, along the North line of the Southwest Quarter of said Section 9, a distance of 1339.60 feet to the Center-West 1/16 Corner of said Section 9; Thence South 89°20'00" East, along the North line of the Southwest quarter of said Section 9, a distance of 1319.47 feet to the Center Quarter of said Section 9; Thence South 89°20'13" East, along the North line of the Southeast quarter of said Section 9, a distance of 446.45 feet, to a point whence the East quarter corner of said Section 9 bears South 89°20'13" East, a distance of 2014.23 feet; Thence South 00°02'03" West, a distance of 2889.03 feet to the South line of said Section 9; Thence South 87°08'22" West, along the South line of said Section 9, a distance of 468.14 feet to the **POINT OF BEGINNING**.

Containing an area of 547.304 acres, more or less.

Have caused the same to be replatted under the name and style of Falls Creek Ranch Units I, II, & III, Amended Plat #2, Project No. 2006-0325 for the purpose of relocating certain pre-existing sites and to eliminate road encroachments, boundary encroachments, and overlapping lot encroachments to conform actual site locations to existing markers. The filing of this Amended Plat results in no increase or decrease in the actual number of sites within the limits of Falls Creek Ranch, and is authorized by the written consent of all affected property owners as reflected by the recordation of that Document recorded in the Office of the La Plata County, Colorado, Clerk and Recorder, under Reception Number 1002765, and further acknowledged hereon by the Falls Creek Homeowners Association and further declares:

**GENERAL DEDICATIONS:**

1. Falls Creek Ranch Association Inc. hereby grants to all lot owner's a non-exclusive easement over common property for the purposes of utilities and road access to each lot, and grants in addition, a non-exclusive easement over common property for meeting applicable health requirements for the location of individual sewage disposal systems. The actual location of utility lines, road access, driveway access and the location of individual sewage disposal systems must be approved by Falls Creek Ranch Association Inc., or by it's applicable committee i.e. Utilities Committee, Architectural Control Committee, Road Committee.
2. Falls Creek Ranch Association Inc. hereby grants to La Plata Electric Association Inc. a non-exclusive easement over common property for the purposes of ingress and egress, installation, operation, maintenance, reconstruction, improvement, replacement, and removal of underground utilities, together with their related equipment.

Falls Creek Ranch Association, Inc. a Colorado nonprofit Corporation  
By: Joh Ritzley, President  
Joh Ritzley-President

Attest: Doralee Matthews Secretary  
Doralee Matthews-Secretary

State of Colorado:

County of La Plata: This plat was acknowledged before me by Joh Ritzley, President and Doralee Matthews Secretary of Falls Creek Ranch Association, Inc. a Colorado nonprofit Corporation on this 10th day of July, 2009 for the aforementioned purposes.

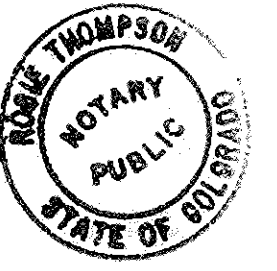

My commission expires: 1-7-2013 Notary: Roscoe Thompson

**COUNTY SURVEYOR'S APPROVAL:**

Approved for content and form only and not for accuracy of surveys, calculations or drafting Pursuant to C.R.S. 1973, 38-51-106 (revised).

By: [Signature]  
County Surveyor, La Plata County, Colorado

Date: 8/18/09

**CERTIFICATION OF APPROVAL:**

This project was reviewed and approved by the Board of County Commissioners of La Plata County, Colorado, on this 17th day of August, 2009.

BOARD OF COUNTY COMMISSIONERS OF LA PLATA COUNTY, COLORADO

By: [Signature]  
Chairperson of the Board

Attest: [Signature]  
Clerk of Record



**CERTIFICATE OF SURVEYOR**

I hereby state that this survey and plat was prepared by me or under my direct responsibility, supervision and checking, and that, in my professional opinion, it is true and correct to the best of my knowledge, belief and information based on the standards of the Professional Land Surveyors practicing in the State of Colorado.

By: [Signature]  
The White, P.L.L.C.  
Professional Land Surveyor 29770

Date: July 30, 2009

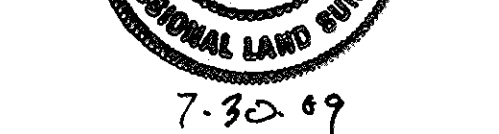

STATE OF COLORADO } SS  
LA PLATA COUNTY }

I hereby state that this instrument was filed for record at 11:00 O'clock P.M. on 8-25, 2009 and duly filed.  
Reception Number 1002766

Linda Daley  
By: [Signature] Deputy

**BECHTOLT**  
ENGINEERING, LLC

P.O. BOX 2683 DURANGO, COLORADO 81302  
(970) 259-7534

SCALE: AS NOTED  
DATE: JUNE 24, 2009  
DRAWN BY: sic/hc/map  
CHECKED BY: TDW

**FALLS CREEK RANCH  
UNITS I, II & III  
AMENDED PLAT #2  
PROJECT NO. 2006-0325**

SECTIONS 9, 16, 17, 20, & 21, T36N, R9W, N.M.P.M.  
SHEET 1 OF 4

THIS PLAT, BEING AN INSTRUMENT OF PROFESSIONAL SERVICE, IS PROTECTED BY COMMON LAW, STATUTORY AND OTHER RESERVED RIGHTS INCLUDING COPYRIGHT. ANY USE OTHER THAN REPRODUCTION FOR ANY PURPOSE WITHOUT WRITTEN CONSENT FROM BECHTOLT ENGINEERING IS UNLAWFUL.

# FALLS CREEK RANCH UNITS I, II & III AMENDED PLAT #2 PROJECT NO. 2006-0325

LOCATED IN SECTIONS 9, 16, 17, 20, & 21, TOWNSHIP 36 NORTH, RANGE 9 WEST, N.M.P.M.

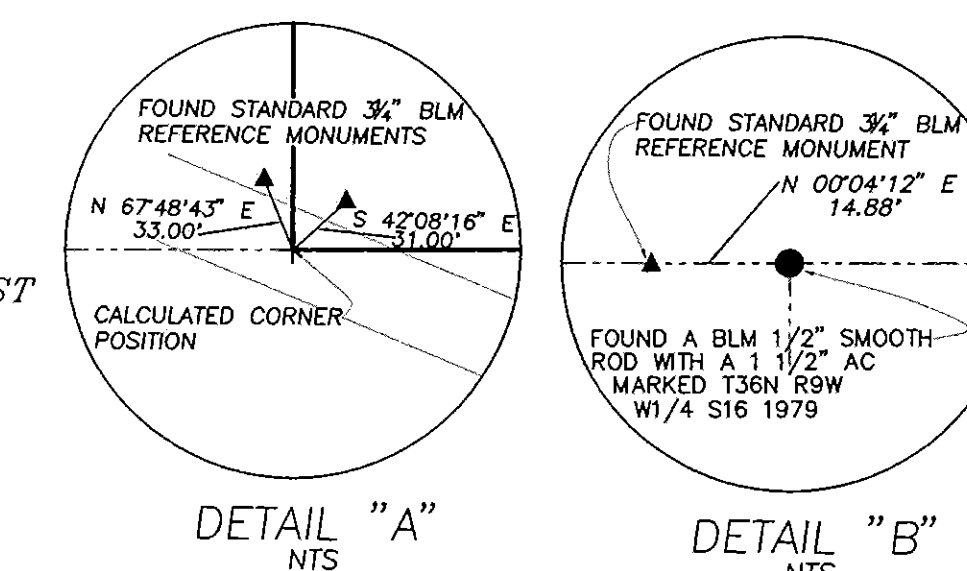
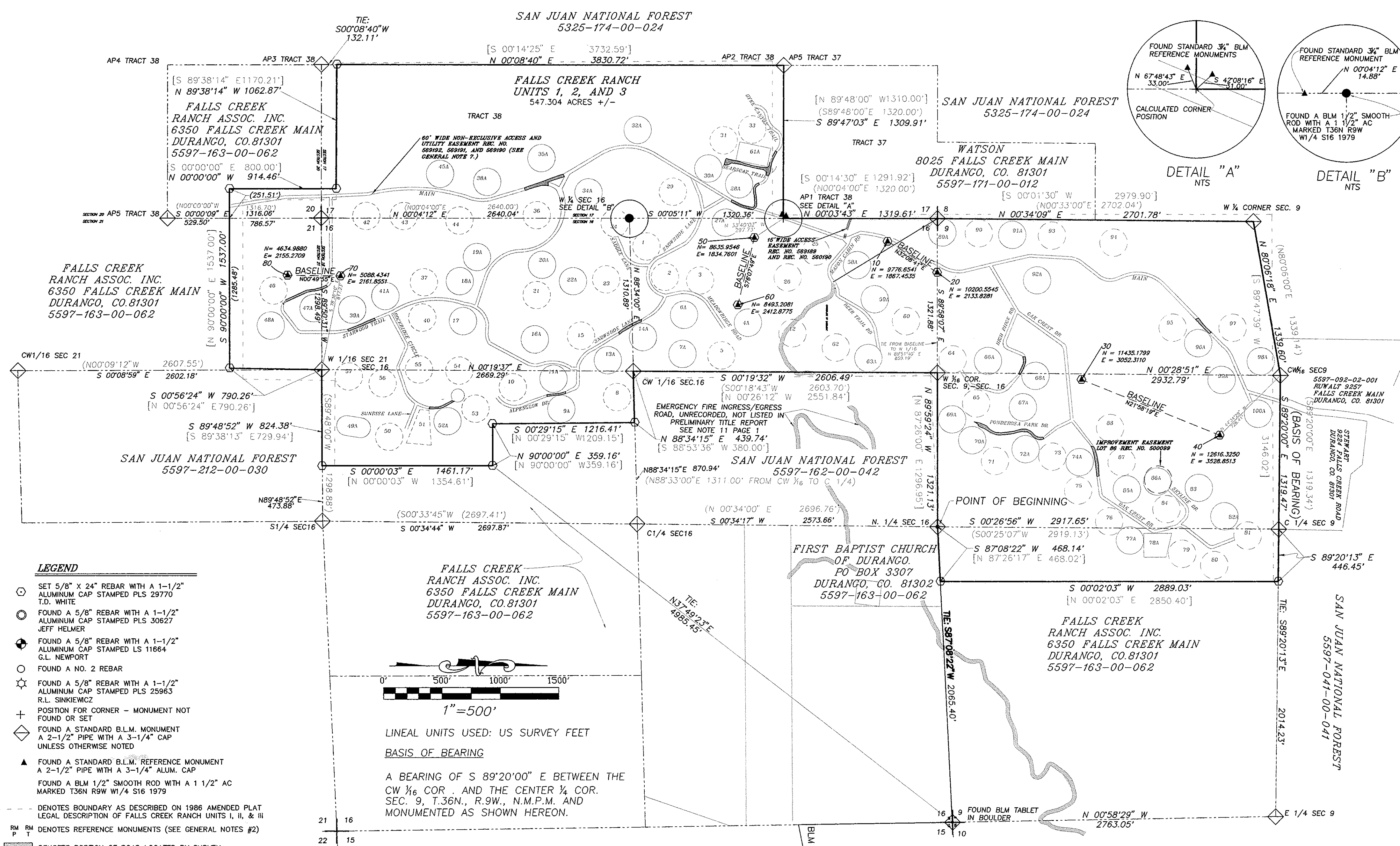

- LEGEND**
- SET 5/8" X 24" REBAR WITH A 1-1/2" ALUMINUM CAP STAMPED PLS 29770 T.D. WHITE
  - FOUND A 5/8" REBAR WITH A 1-1/2" ALUMINUM CAP STAMPED PLS 30627 JEFF HELMER
  - ⊕ FOUND A 5/8" REBAR WITH A 1-1/2" ALUMINUM CAP STAMPED LS 11664 G.L. NEWPORT
  - FOUND A NO. 2 REBAR
  - ☆ FOUND A 5/8" REBAR WITH A 1-1/2" ALUMINUM CAP STAMPED PLS 25963 R.L. SINKIEWICZ
  - ⊕ POSITION FOR CORNER - MONUMENT NOT FOUND OR SET
  - ◇ FOUND A STANDARD B.L.M. MONUMENT A 2-1/2" PIPE WITH A 3-1/4" CAP UNLESS OTHERWISE NOTED
  - ▲ FOUND A STANDARD B.L.M. REFERENCE MONUMENT A 2-1/2" PIPE WITH A 3-1/4" ALUM. CAP
  - FOUND A BLM 1/2" SMOOTH ROD WITH A 1 1/2" AC MARKED T36N R9W W1/4 S16 1979
  - DENOTES BOUNDARY AS DESCRIBED ON 1986 AMENDED PLAT LEGAL DESCRIPTION OF FALLS CREEK RANCH UNITS I, II, & III
  - DENOTES REFERENCE MONUMENTS (SEE GENERAL NOTES #2)
  - ▨ DENOTES PORTION OF ROAD LOCATED BY SURVEY
  - A DENOTES LOT THAT HAS BEEN AMENDED
  - Ⓢ SET #5 REBAR WITH 1.5" ALUM. CAP MARKED BECHTOLT CONTROL
  - ( ) RECORD BLM
  - [ ] RECORD 1986 AMENDED PLAT OF FALLS CREEK RANCH, UNITS I, II, AND III
  - (NTS) NOT TO SCALE

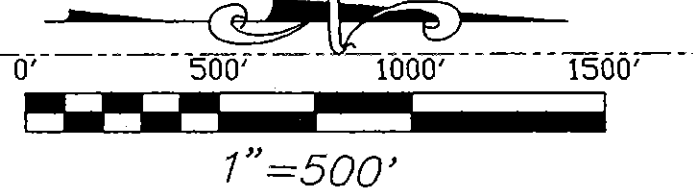

LINEAL UNITS USED: US SURVEY FEET  
BASIS OF BEARING  
A BEARING OF S 89°20'00" E BETWEEN THE CW 1/6 COR. AND THE CENTER 1/4 COR. SEC. 9, T.36N., R.9W., N.M.P.M. AND MONUMENTED AS SHOWN HEREON.

THE PURPOSE OF THIS AMENDED PLAT IS TO MOVE LOTS 4, 6, 7, 9, 11, 13, 14, 16, 17, 18, 19, 20, 22, 27, 28, 30, 32, 34, 35, 38, 39, 41, 45, 47, 48, 49, 52, 58, 59, 61, 63, 66, 67, 68, 69, 70, 72, 74, 77, 78, 82, 83, 85, 86, 89, 91, 92, 96, 98, 99, AND 100 TO CORRECT THE ENCROACHMENTS OF THE STRUCTURES INTO THE COMMON AREAS AND THE ENCROACHMENTS OF THE ROADWAYS INTO THE EXISTING LOTS.

LOT NO.	NORTHING	EASTING	NORTHING	EASTING
1	2710.00	1910.00		
2	7868.60	2171.30		
3	8169.39	2201.925		
4			8579.64	2565.00
5	8350.70	2843.40		
6	8031.79	2496.91	COORDINATES NOT CHANGED	
7	8017.80	2930.80	COORDINATES NOT CHANGED	
8	7456.49	3200.165		
9			6978.99	3301.08
10	8561.50	3115.40		
11	6912.70	3042.48	COORDINATES NOT CHANGED	
12	8961.645	2854.54		
13			7378.18	2881.80
14			7679.39	2686.59
15	7148.00	2875.00		
16	6752.01	2706.10	COORDINATES NOT CHANGED	
17			6137.48	2548.39
18			6199.48	2201.10
19	6227.00	2000.00	COORDINATES NOT CHANGED	
20	2815.00	2067.00	COORDINATES NOT CHANGED	
21	6768.60	2327.23		
22			7079.85	2208.24
23	7364.00	2192.50		
24	7638.00	1710.00		
25	8169.39	1924.70		
26	8920.555	2177.18		
27			8369.89	1705.98
28			8504.55	1377.12
29	7936.80	1440.69		
30			8240.92	1242.30
31	8372.60	1001.30		
32	7635.45	911.77	COORDINATES NOT CHANGED	
33	8616.90	908.60		
34			7214.24	1445.98
35			6810.38	1152.17
36	6770.00	1641.60		
37	5802.22	2216.98		
38			6345.52	1355.67
39			5182.71	2450.24
40	5788.62	2519.18		
41			5472.04	2334.24
42	5309.05	1647.21		
43	5679.72	1648.23		
44	6107.16	1686.74		
45			5942.21	1286.77
46	4513.86	2285.98		
47			4855.90	2438.06
48			4490.32	2565.85
49			SEE PLAT FOR COORDINATES	
50	5503.72	3536.95		
51	SEE PLAT FOR COORDINATES			
52			6003.65	3408.80
53	6243.12	3298.31		
54	6105.41	2972.40		
55	5760.38	2961.62		
56	5448.77	3080.86		
57	5158.28	3021.78		
58			8514.85	2071.66
59			8665.37	2364.67
60	9933.70	2552.40		
61			SEE PLAT FOR COORDINATES	
62	9332.57	2777.25		
63			9610.56	2866.66
64	10332.90	2878.00		
65	10533.08	3255.44		
66	10634.10	2892.50	COORDINATES NOT CHANGED	
67	10933.00	3288.00	COORDINATES NOT CHANGED	
68			11041.27	3018.97
69			10327.64	3392.24
70			10499.03	3570.70
71	10693.90	3748.30		
72			10255.24	3648.07
73	11184.20	3711.70		
74			11412.22	3759.36
75	11404.20	4003.90		
76	11670.94	4269.54		
77			11846.74	4431.63
78			SEE PLAT FOR COORDINATES	
79	12293.60	4546.10		
80	12568.00	4422.80		
81	12853.40	4391.30		
82			12655.05	4225.28
83			12436.09	3981.14
84	12160.03	4163.92		
85			11821.53	3893.78
86			12081.46	3926.70
87	11721.10	3758.70		
88	11678.30	3468.80		
89			10244.58	1790.85
90	10557.10	1798.10		
91			10842.75	1812.10
92			11054.54	2202.52
93	11182.30	1818.60		
94	11268.80	1878.50		
95	12214.30	2608.10		
96			12432.34	2741.02
97	12726.24	2810.29		
98			12866.73	2886.82
99			12632.10	3055.70
100			12943.44	3345.39



**BECHTOLT**  
ENGINEERING, LLC  
P.O. BOX 2683 DURANGO, COLORADO 81302  
(970) 259-7534

SCALE: AS NOTED	FALLS CREEK RANCH UNITS I, II & III AMENDED PLAT #2 PROJECT NO. 2006-0325
DATE: JUNE 24, 2009	
DRAWN BY: slc/hc/map	
CHECKED BY: TDW	SHEET 2 OF 4

THIS PLAT, BEING AN INSTRUMENT OF PROFESSIONAL SERVICE, IS PROTECTED BY COMMON LAW, STATUTORY AND OTHER RESERVED RIGHTS INCLUDING COPYRIGHT. ANY USE OTHER THAN REPRODUCTION FOR ANY PURPOSE WITHOUT WRITTEN CONSENT FROM BECHTOLT ENGINEERING IS UNLAWFUL.

#1002266

# FALLS CREEK RANCH

## UNITS I, II & III AMENDED PLAT #2 PROJECT NO. 2006-0325

LOCATED IN SECTIONS 9, 16, 17, 20, & 21, TOWNSHIP 36 NORTH, RANGE 9 WEST, N.M.P.M.

SAN JUAN NATIONAL FOREST  
5325-174-00-024  
[S 00°14'25" E 3732.59']  
[N 00°08'40" E 3830.72']

### FALLS CREEK RANCH

#### UNITS 1, 2, AND 3

547.304 ACRES +/-

TRACT 38

LINE TABLE THIS SHEET ONLY

NUMBER	DIRECTION	DISTANCE	NUMBER	DIRECTION	DISTANCE
L1	S 90°00'00" W	117.75 FT	L33	N 00°00'08" W	117.75 FT
L2	S 66°59'33" E	127.93 FT	L34	N 23°00'35" W	127.93 FT
L3	S 90°00'00" W	117.75 FT	L35	N 20°00'00" E	117.75 FT
L4	N 66°59'33" E	127.93 FT	L36	N 43°00'27" E	127.93 FT
L5	N 03°52'19" E	117.75 FT	L37	S 00°00'00" W	117.75 FT
L6	N 19°08'09" W	127.93 FT	L38	S 23°00'27" E	127.93 FT
L7	S 90°00'00" W	117.75 FT	L39	N 89°59'35" E	117.75 FT
L8	S 66°59'33" W	127.93 FT	L40	S 66°59'38" E	127.93 FT
L9	S 00°00'00" W	117.75 FT	L41	N 00°00'00" W	117.75 FT
L10	S 23°00'27" W	127.93 FT	L42	N 23°00'27" W	127.93 FT
L11	S 89°59'40" W	117.75 FT	L43	N 07°28'38" E	40.46 FT
L12	N 67°03'53" W	127.93 FT	L44	S 70°32'40" W	20.84 FT
L13	S 47°34'41" E	96.84 FT	L45	S 39°08'17" E	3.56 FT
L14	N 89°59'11" E	117.75 FT	L46	N 58°49'38" W	6.22 FT
L15	N 66°58'44" E	127.93 FT	L47	N 32°41'07" W	72.75 FT
L16	S 45°00'00" W	117.75 FT	L48	S 70°19'59" W	11.58 FT
L17	S 21°59'33" W	127.93 FT	L49	S 11°06'56" E	4.81 FT
L18	S 02°47'06" E	115.66 FT	L50	N 36°30'16" W	4.31 FT
L19	S 45°00'00" E	117.75 FT	L51	N 36°43'13" W	38.04 FT
L20	S 21°59'33" E	127.93 FT	L52	N 49°12'18" W	125.21 FT
L21	N 89°59'56" W	117.75 FT	L53	S 02°37'10" W	10.07 FT
L22	S 66°59'38" W	127.93 FT	L54	N 00°24'31" W	255.57 FT
L23	S 23°00'27" W	127.93 FT	L55	S 25°19'46" E	5.19 FT
L24	S 00°00'00" W	117.75 FT	L56	S 46°40'39" E	24.84 FT
L25	S 90°00'00" E	117.75 FT	L57	S 90°00'00" E	117.75 FT
L26	S 66°59'33" E	127.93 FT	L58	S 66°59'33" E	127.93 FT
L27	S 90°00'00" W	117.75 FT	L59	S 09°11'23" W	122.72 FT
L28	S 66°59'33" W	127.93 FT	L60	N 09°11'23" W	122.72 FT
L29	S 90°00'00" W	117.75 FT	L61	S 11°52'12" E	272.25 FT
L30	S 66°59'33" W	127.93 FT	L62	S 78°07'48" E	160.00 FT
L31	S 90°00'00" E	117.75 FT	L63	S 11°52'12" E	272.25 FT
L32	S 66°59'33" E	127.93 FT	L64	S 78°07'48" E	160.00 FT

FALLS CREEK RANCH  
ASSOC. INC.  
5597-163-00-062

[S 00°00'00" E 800.00']  
[N 00°00'00" W 914.46']

FALLS CREEK RANCH ASSOC. INC.  
6350 FALLS CREEK MAIN  
DURANGO, CO. 81301  
5597-163-00-062

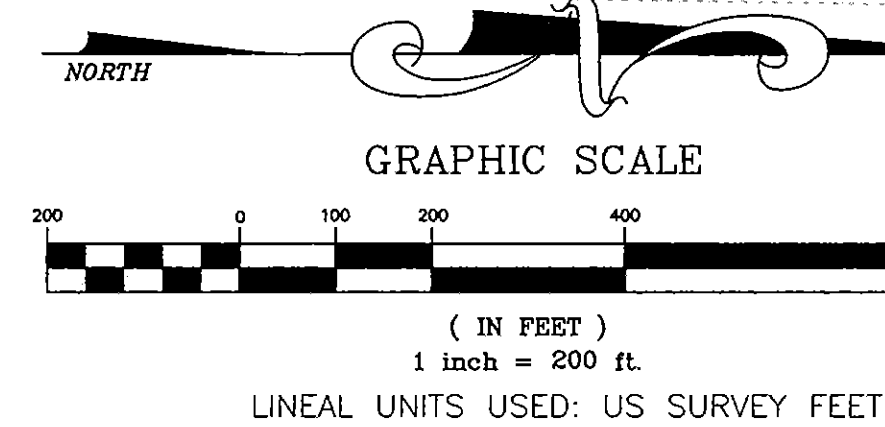

**BASIS OF BEARING**  
A BEARING OF S 89°20'00" E BETWEEN THE CW 1/4 COR. AND THE CENTER 1/4 COR. SEC. 9, T.36N., R.9W., N.M.P.M. AND MONUMENTED AS SHOWN HEREON.

SAN JUAN NATIONAL FOREST  
5597-212-00-030

FALLS CREEK RANCH ASSOC. INC.  
6350 FALLS CREEK MAIN  
DURANGO, CO. 81301  
5597-163-00-062

**NOTE:**  
THE PURPOSE OF THIS AMENDED PLAT IS TO MOVE LOTS 4, 6, 7, 9, 11, 13, 14, 16, 17, 18, 19, 20, 22, 27, 28, 30, 32, 34, 35, 38, 39, 41, 45, 47, 48, 49, 52, 58, 59, 61, 63, 66, 67, 68, 69, 70, 72, 74, 77, 78, 82, 83, 85, 86, 89, 91, 92, 96, 98, 99, AND 100 TO CORRECT THE ENCROACHMENTS OF THE STRUCTURES INTO THE COMMON AREAS AND THE ENCROACHMENTS OF THE ROADWAYS INTO THE EXISTING LOTS.

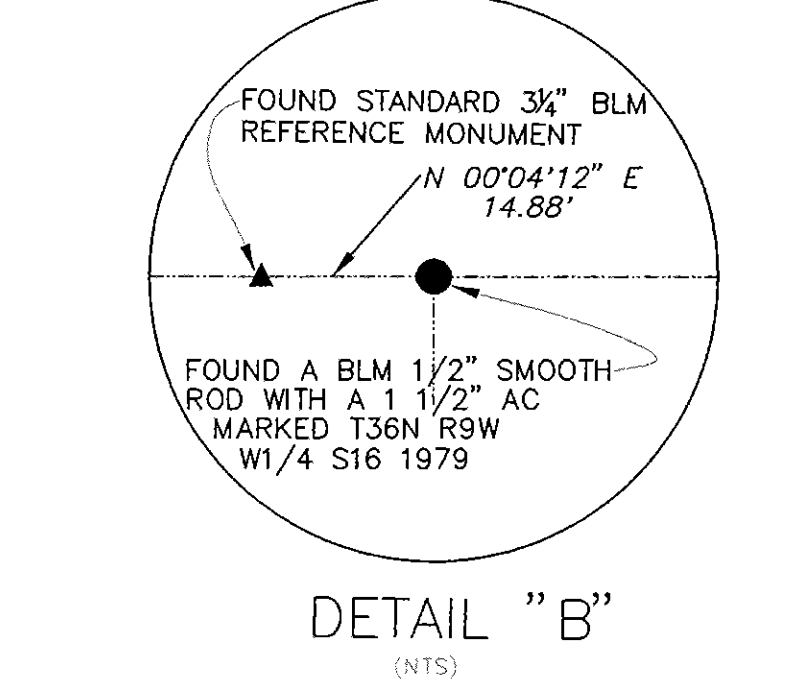
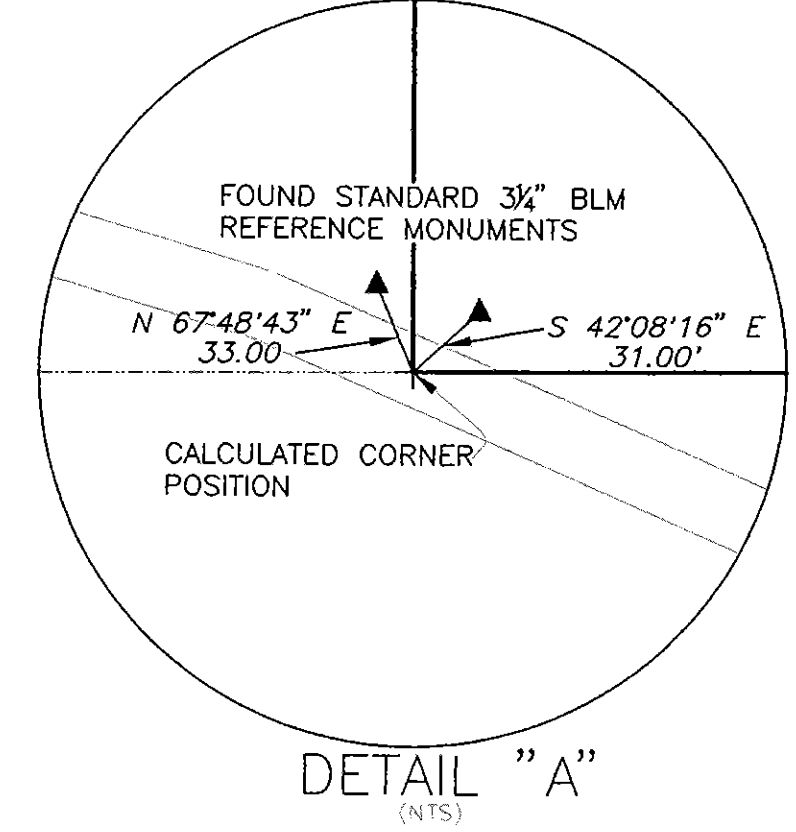

- LEGEND**
- SET 5/8" X 24" REBAR WITH A 1-1/2" ALUMINUM CAP STAMPED PLS 29770 T.D. WHITE
  - FOUND A 5/8" REBAR WITH A 1-1/2" ALUMINUM CAP STAMPED PLS 30627 JEFF HELMER
  - FOUND A 5/8" REBAR WITH A 1-1/2" ALUMINUM CAP STAMPED LS 11664 G.L. NEWPORT
  - FOUND A NO. 2 REBAR
  - FOUND A 5/8" REBAR WITH A 1-1/2" ALUMINUM CAP STAMPED PLS 25963 R.L. SINKIEWICZ
  - + POSITION FOR CORNER - MONUMENT NOT FOUND OR SET
  - ◇ FOUND A STANDARD B.L.M. MONUMENT A 2-1/2" PIPE WITH A 3-1/4" CAP UNLESS OTHERWISE NOTED
  - ▲ FOUND A STANDARD B.L.M. REFERENCE MONUMENT A 2-1/2" PIPE WITH A 3-1/4" ALUM. CAP
  - FOUND A BLM 1/2" SMOOTH ROD WITH A 1 1/2" AC MARKED T36N R9W W1/4 S16 1979
- DENOTES BOUNDARY AS DESCRIBED ON 1986 AMENDED PLAT LEGAL DESCRIPTION OF FALLS CREEK RANCH UNITS I, II, & III
- RM RM DENOTES REFERENCE MONUMENTS (SEE GENERAL NOTES #2)
- DENOTES PORTION OF ROAD LOCATED BY SURVEY
- A DENOTES LOT THAT HAS BEEN AMENDED
- SET #5 REBAR WITH 1.5" ALUM. CAP MARKED BECHTOLT CONTROL
  - ( ) RECORD BLM
  - ( ) RECORD 1986 AMENDED PLAT OF FALLS CREEK RANCH, UNITS I, II, AND III
  - (NTS) NOT TO SCALE

**BECHTOLT**  
ENGINEERING, LLC

P.O. BOX 2683 DURANGO, COLORADO 81302  
(970) 259-7534

SCALE: 1" = 200 feet  
DATE: JUNE 24, 2009  
DRAWN BY: slc/hc/map  
CHECKED BY: TDW

**FALLS CREEK RANCH**  
UNITS I, II & III  
AMENDED PLAT #2  
PROJECT NO. 2006-0325

SHEET 3 OF 4

THIS PLAT, BEING AN INSTRUMENT OF PROFESSIONAL SERVICE, IS PROTECTED BY COMMON LAW, STATUTORY AND OTHER RESERVED RIGHTS INCLUDING COPYRIGHT. ANY USE OTHER THAN REPRODUCTION FOR ANY PURPOSE WITHOUT WRITTEN CONSENT FROM BECHTOLT ENGINEERING IS UNLAWFUL.

# FALLS CREEK RANCH UNITS I, II & III AMENDED PLAT #2 PROJECT NO. 2006-0325

LOCATED IN SECTIONS 9, 16, 17, 20, & 21, TOWNSHIP 36 NORTH, RANGE 9 WEST, N.M.P.M.

WATSON  
8025 FALLS CREEK MAIN  
DURANGO, CO. 81301  
5597-171-00-012

TRACT 37

SAN JUAN NATIONAL FOREST  
5325-174-00-024

THE PURPOSE OF THIS AMENDED PLAT IS TO MOVE LOTS 4, 6, 7, 9, 11, 13, 14, 16, 17, 18, 19, 20, 22, 27, 28, 30, 32, 34, 35, 38, 39, 41, 45, 47, 48, 49, 52, 58, 59, 61, 63, 66, 67, 68, 69, 70, 72, 74, 77, 78, 82, 83, 85, 86, 89, 91, 92, 96, 98, 99, AND 100 TO CORRECT THE ENCROACHMENTS OF THE STRUCTURES INTO THE COMMON AREAS AND THE ENCROACHMENTS OF THE ROADWAYS INTO THE EXISTING LOTS.

LOT NO.	NORTHING	EASTING	NORTHING	EASTING
1	7710.00	1910.00		
2	7868.80	2171.30		
3	8169.39	2201.925		
4			8579.64	2565.00
5	8350.70	2843.40		
6	8031.79	2496.81	COORDINATES NOT CHANGED	
7	8017.80	2830.80	COORDINATES NOT CHANGED	
8	7456.49	3200.165		
9			6978.99	3301.08
10	6563.50	3115.40		
11	6912.70	3042.48	COORDINATES NOT CHANGED	
12	8981.645	2854.54		
13			7378.18	2883.80
14			7679.39	2686.58
15	7148.00	2675.00		
16	6752.01	2706.10	COORDINATES NOT CHANGED	
17			6137.48	2549.39
18			6109.48	2207.10
19	6257.00	2000.00	COORDINATES NOT CHANGED	
20	6816.00	2087.00	COORDINATES NOT CHANGED	
21	6768.60	2327.23		
22			7079.85	2208.24
23	7364.00	2192.50		
24	7438.00	1710.00		
25	9160.99	1954.70		
26	8920.555	2177.18		
27			8389.89	1705.98
28			8504.55	1377.12
29	7936.80	1440.69		
30			8240.92	1242.30
31	8372.60	1001.20		
32	7635.45	911.77	COORDINATES NOT CHANGED	
33	8616.90	908.60		
34			7214.24	1445.98
35			6810.38	1152.17
36	6770.00	1641.60		
37	5802.22	2216.98		
38			6345.52	1355.67
39			5187.71	2450.24
40	5788.62	2519.18		
41			5472.04	2334.24
42	5309.05	1647.21		
43	5629.72	1648.23		
44	6107.16	1686.74		
45			5942.21	1286.77
46	4513.86	2285.98		
47			4855.90	2438.06
48			4490.32	2585.85
49			SEE PLAT FOR COORDINATES	
50	5503.72	3538.95		
51			SEE PLAT FOR COORDINATES	
52			6003.85	3405.80
53	6243.12	3298.31		
54	6105.41	2872.40		
55	5760.38	2961.62		
56	5448.77	3080.86		
57	5158.29	3021.78		
58			9514.85	2071.66
59			9665.37	2364.67
60	9833.70	2552.40		
61			SEE PLAT FOR COORDINATES	
62	9332.57	2777.25		
63			9610.56	2866.66
64	10332.90	2879.00		
65	10533.06	3255.44		
66	10634.20	2892.30	COORDINATES NOT CHANGED	
67	10933.00	3289.00	COORDINATES NOT CHANGED	
68			11041.27	3019.97
69			10327.64	3392.24
70			10499.03	3570.70
71	10693.90	3749.30		
72			10955.24	3648.07
73	11184.20	3711.70		
74			11417.72	3759.36
75	11404.70	4003.90		
76	11670.94	4269.54		
77			11846.74	4431.63
78			SEE PLAT FOR COORDINATES	
79	12283.60	4546.10		
80	12568.00	4642.80		
81	12853.40	4391.30		
82			12655.05	4225.28
83			12436.09	3981.14
84	12160.03	4163.92		
85			11821.53	3993.76
86			12081.46	3926.70
87	11777.10	3758.70		
88	11679.30	3466.80		
89			10244.58	1790.85
90	10557.10	1798.10		
91			10842.75	1812.10
92			11054.54	2202.52
93	11182.30	1818.60		
94	11708.90	1879.50		
95	12214.30	2609.10		
96			12432.34	2741.02
97	12726.24	2610.29		
98			12966.73	2896.82
99			12632.10	3055.70
100			12943.44	3345.39

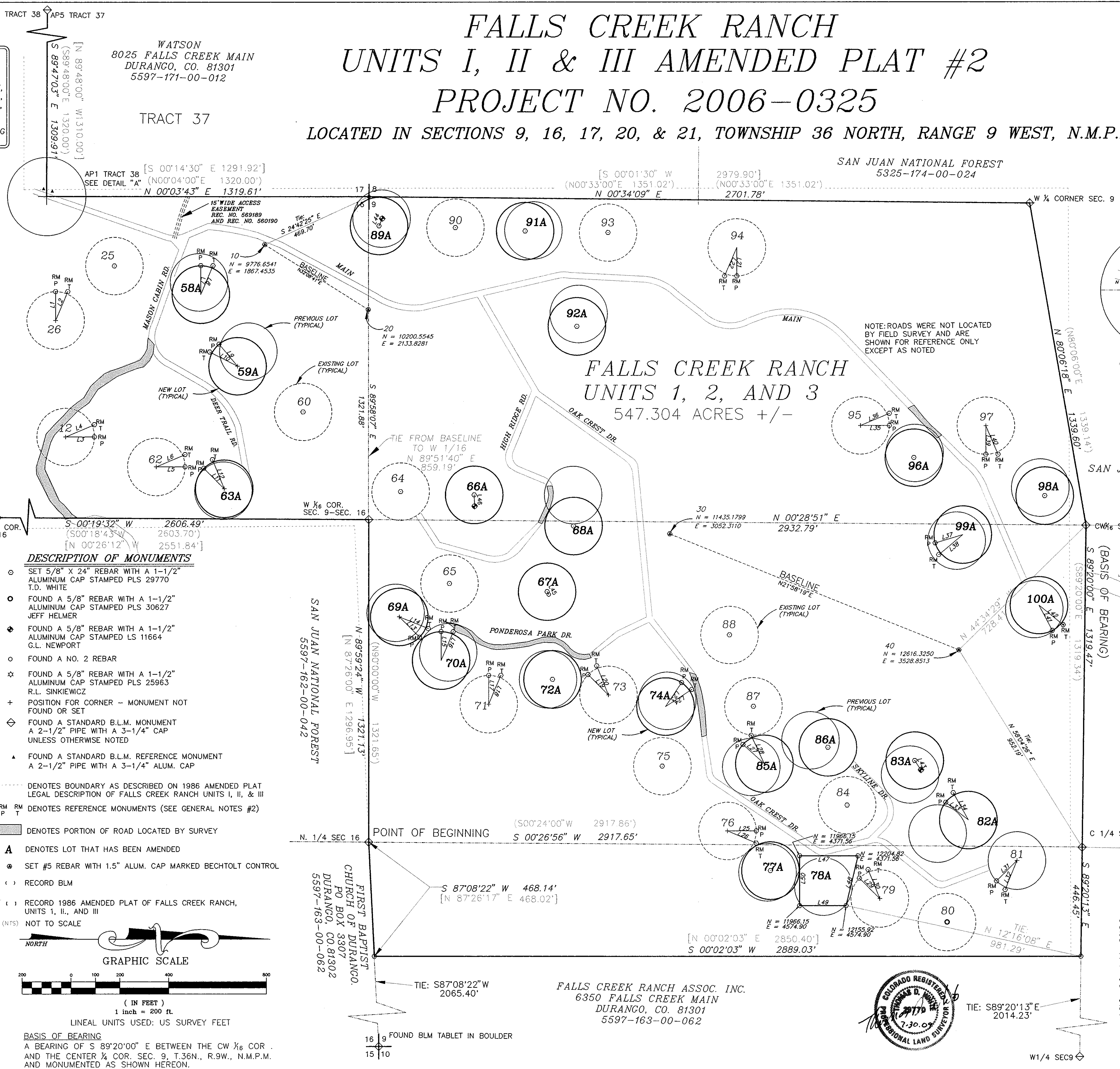

- DESCRIPTION OF MONUMENTS**
- SET 5/8" X 24" REBAR WITH A 1-1/2" ALUMINUM CAP STAMPED PLS 29770 T.D. WHITE
  - FOUND A 5/8" REBAR WITH A 1-1/2" ALUMINUM CAP STAMPED PLS 30627 JEFF HELMER
  - ◆ FOUND A 5/8" REBAR WITH A 1-1/2" ALUMINUM CAP STAMPED LS 11664 G.L. NEWPORT
  - FOUND A NO. 2 REBAR
  - ☆ FOUND A 5/8" REBAR WITH A 1-1/2" ALUMINUM CAP STAMPED PLS 25963 R.L. SINKIEWICZ
  - + POSITION FOR CORNER - MONUMENT NOT FOUND OR SET
  - ◇ FOUND A STANDARD B.L.M. MONUMENT A 2-1/2" PIPE WITH A 3-1/4" CAP UNLESS OTHERWISE NOTED
  - ▲ FOUND A STANDARD B.L.M. REFERENCE MONUMENT A 2-1/2" PIPE WITH A 3-1/4" ALUM. CAP
  - DENOTES BOUNDARY AS DESCRIBED ON 1986 AMENDED PLAT LEGAL DESCRIPTION OF FALLS CREEK RANCH UNITS I, II, & III
  - RM P T DENOTES REFERENCE MONUMENTS (SEE GENERAL NOTES #2)
  - ▨ DENOTES PORTION OF ROAD LOCATED BY SURVEY
  - A DENOTES LOT THAT HAS BEEN AMENDED
  - ⊙ SET #5 REBAR WITH 1.5" ALUM. CAP MARKED BECHTOLT CONTROL
  - ( ) RECORD BLM
  - ( ) RECORD 1986 AMENDED PLAT OF FALLS CREEK RANCH, UNITS I, II, AND III
  - (NTS) NOT TO SCALE

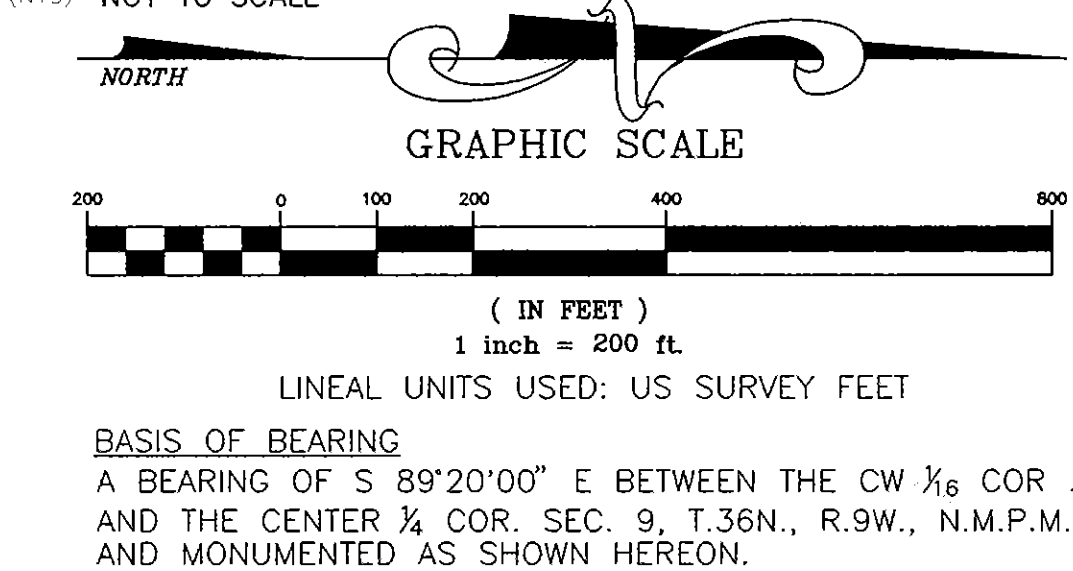

LINE TABLE THIS SHEET ONLY

NUMBER	DIRECTION	DISTANCE
L1	S 90°00'00" E	117.75 FT
L2	S 66°59'33" E	127.93 FT
L3	S 00°00'00" E	117.75 FT
L4	S 23°00'27" E	127.93 FT
L5	S 00°00'00" E	117.75 FT
L6	S 23°00'27" E	127.93 FT
L7	N 89°59'53" E	117.75 FT
L8	S 66°59'40" E	127.93 FT
L9	N 50°00'02" E	117.75 FT
L10	N 26°59'59" E	127.93 FT
L11	N 44°59'59" E	117.75 FT
L12	N 68°00'26" E	127.93 FT
L13	S 45°00'03" W	117.75 FT
L14	S 21°59'36" W	127.93 FT
L15	S 89°59'52" E	117.75 FT
L16	S 67°06'03" E	127.37 FT
L17	S 90°00'00" E	117.75 FT
L18	S 66°59'33" E	127.93 FT
L19	N 45°00'00" E	117.75 FT
L20	N 68°00'27" E	127.93 FT
L21	S 90°00'00" W	117.75 FT
L22	S 66°59'52" E	127.95 FT
L23	N 42°10'25" W	117.75 FT
L24	S 33°06'44" E	127.93 FT
L25	S 00°00'00" W	117.75 FT
L26	S 23°00'27" W	127.93 FT
L27	N 42°10'25" E	117.75 FT
L28	N 65°10'52" E	127.93 FT
L29	N 45°00'00" E	117.75 FT
L30	N 68°00'27" E	127.93 FT
L31	N 45°00'00" W	117.75 FT
L32	N 68°00'27" W	127.93 FT
L33	N 38°05'46" E	117.75 FT
L34	N 61°06'13" E	127.93 FT
L35	S 00°00'00" W	117.75 FT
L36	S 23°00'27" E	127.93 FT
L37	N 16°56'02" W	117.75 FT
L38	N 39°56'28" W	127.93 FT
L39	S 90°00'00" W	117.75 FT
L40	S 66°59'33" W	127.93 FT
L41	S 62°19'05" W	117.75 FT
L42	S 39°18'38" W	127.93 FT
L43	S 56°41'08" W	45.90 FT
L44	S 66°42'19" E	32.54 FT
L45	N 61°00'42" E	13.39 FT
L46	N 87°50'21" E	46.13 FT
L47	N 00°00'00" W	238.67 FT
L48	S 76°28'41" E	209.14 FT
L49	S 00°00'00" E	189.77 FT
L50	N 90°00'00" W	203.34 FT

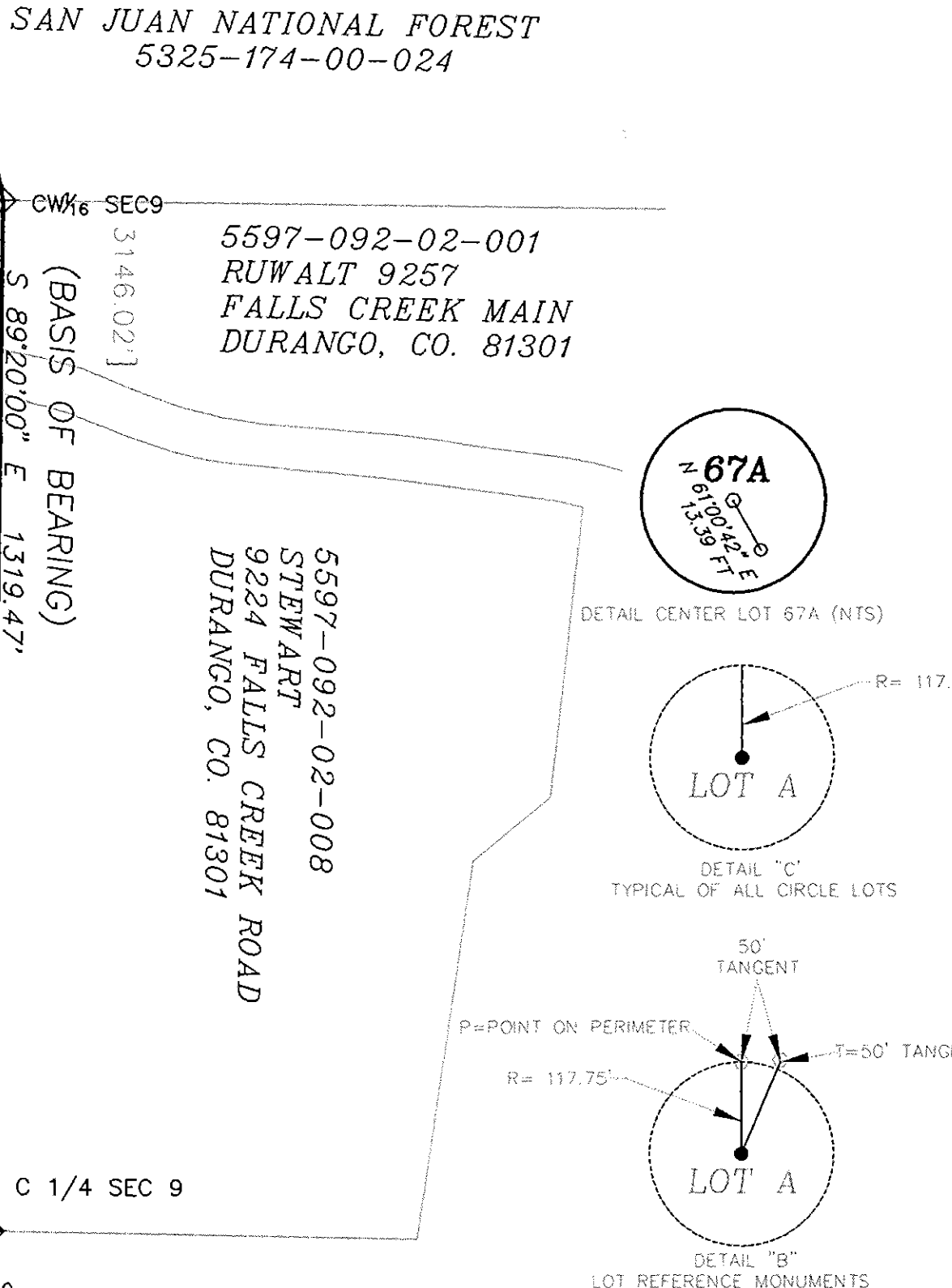
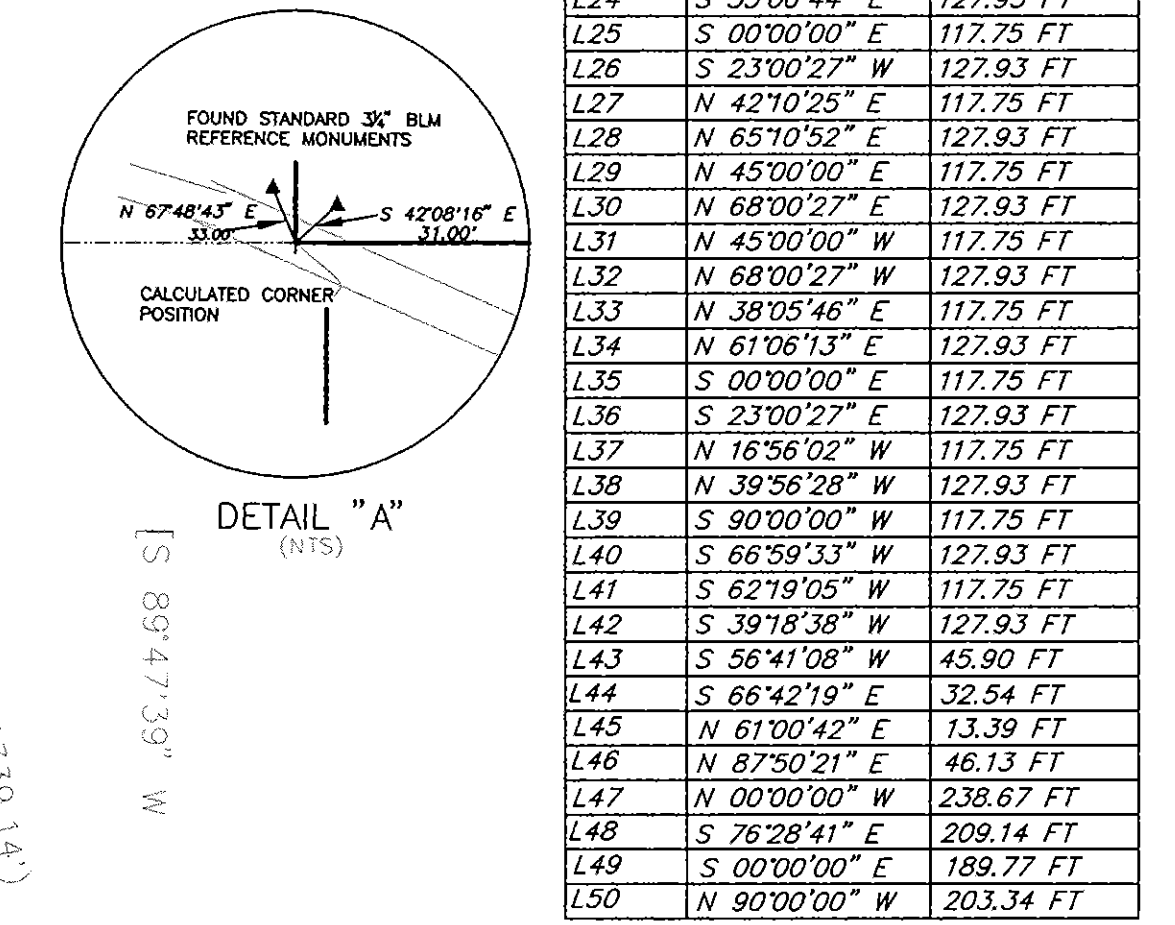

FALLS CREEK RANCH ASSOC. INC.  
6350 FALLS CREEK MAIN  
DURANGO, CO. 81301  
5597-163-00-062



1002266

**BECHTOLT**  
ENGINEERING, LLC  
P.O. BOX 2683 DURANGO, COLORADO 81302  
(970) 259-7534

SCALE: 1" = 200 feet  
DATE: JUNE 24, 2009  
DRAWN BY: slc/hc/map  
CHECKED BY: TDW

FALLS CREEK RANCH  
AMENDED PLAT #2  
UNITS I, II & III  
PROJECT NO. 2006-0325  
SECTIONS 9, 16, 17, 20 & 21, T36N., R9W., N.M.P.M.  
SHEET 4 OF 4

THIS PLAT, BEING AN INSTRUMENT OF PROFESSIONAL SERVICE, IS PROTECTED BY COMMON LAW, STATUTORY AND OTHER RESERVED RIGHTS INCLUDING COPYRIGHT. ANY USE OTHER THAN REPRODUCTION FOR ANY PURPOSE WITHOUT WRITTEN CONSENT FROM BECHTOLT ENGINEERING IS UNLAWFUL.